

METUNING spol. s. r. o.



Cardan parts and accessories
presentation

CONNECTING FLANGES

DIN 58 – DIN 435

PROFILE FOR TORQUE TRANSMISSION

key groove DIN 6885

involute spline DIN 5480

involute spline DIN 5482

involute spline ANSI B92.1

parallel spline DIN ISO 14

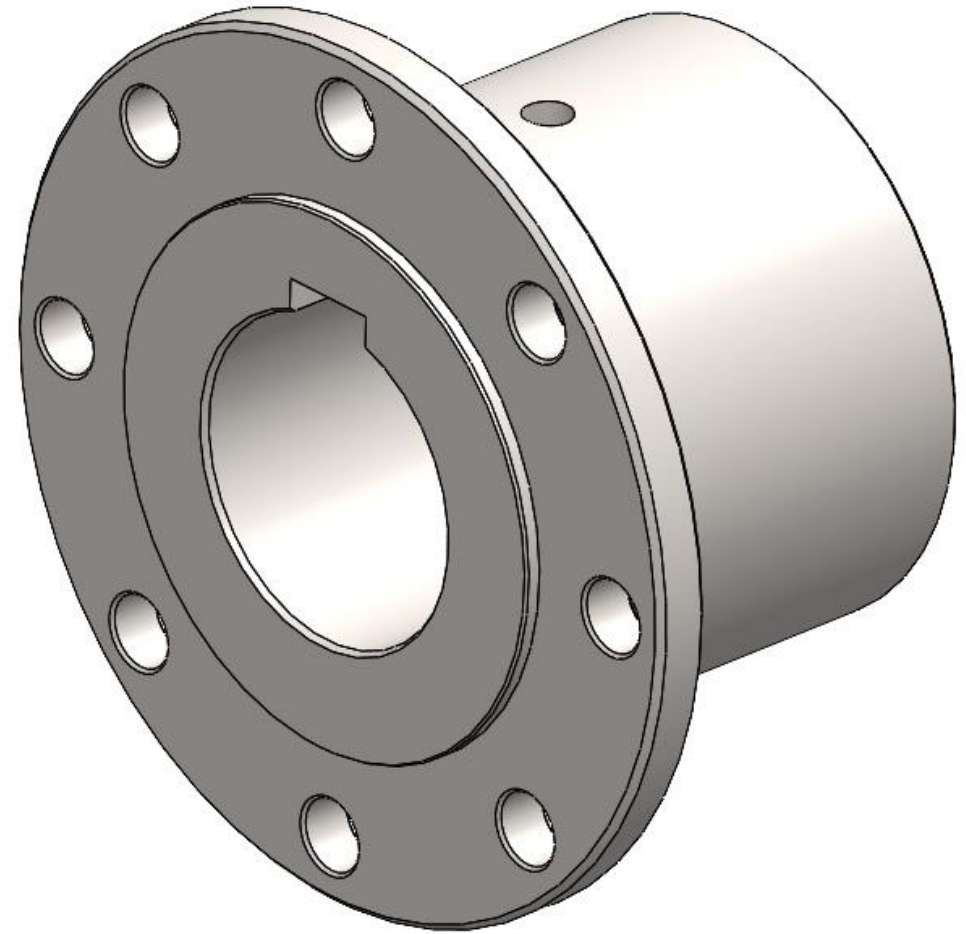

CONNECTING FLANGES

SAE 1100 – 1900

PROFILE FOR TORQUE
TRANSMISSION

key groove DIN 6885

involute spline DIN 5480

involute spline DIN 5482

involute spline ANSI B92.1

parallel spline DIN ISO14

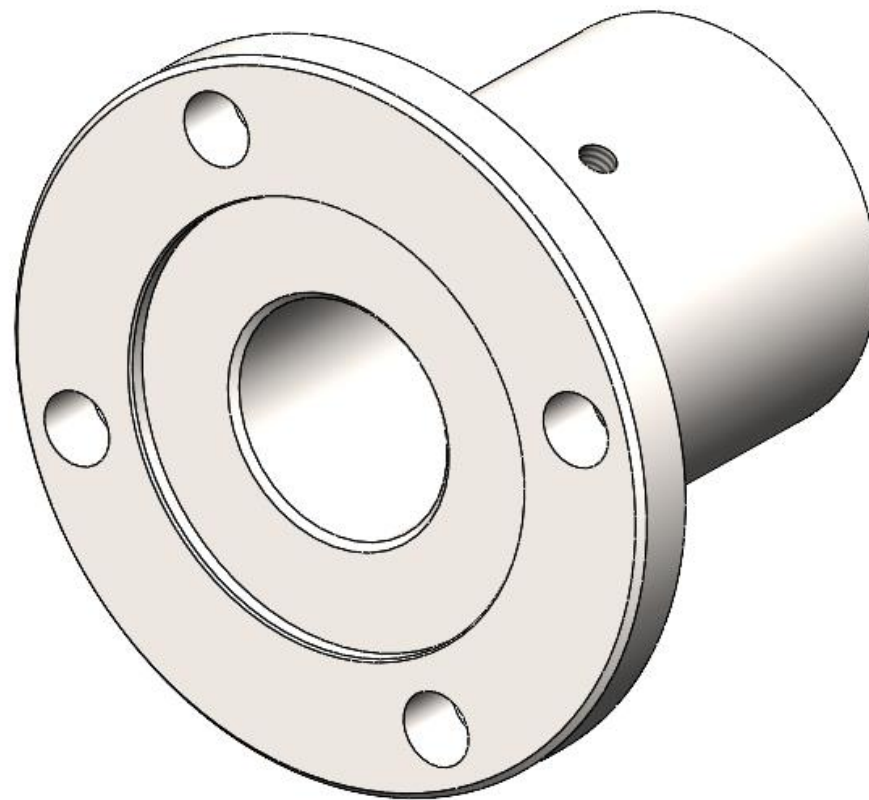

CONNECTING FLANGES FOR CONSTANT VELOCITY SHAFTS

PROFILE FOR TORQUE TRANSMISSION

key groove DIN 6885

involute spline DIN 5480

involute spline DIN 5482

involute spline ANSI B92.1

parallel spline DIN ISO 14

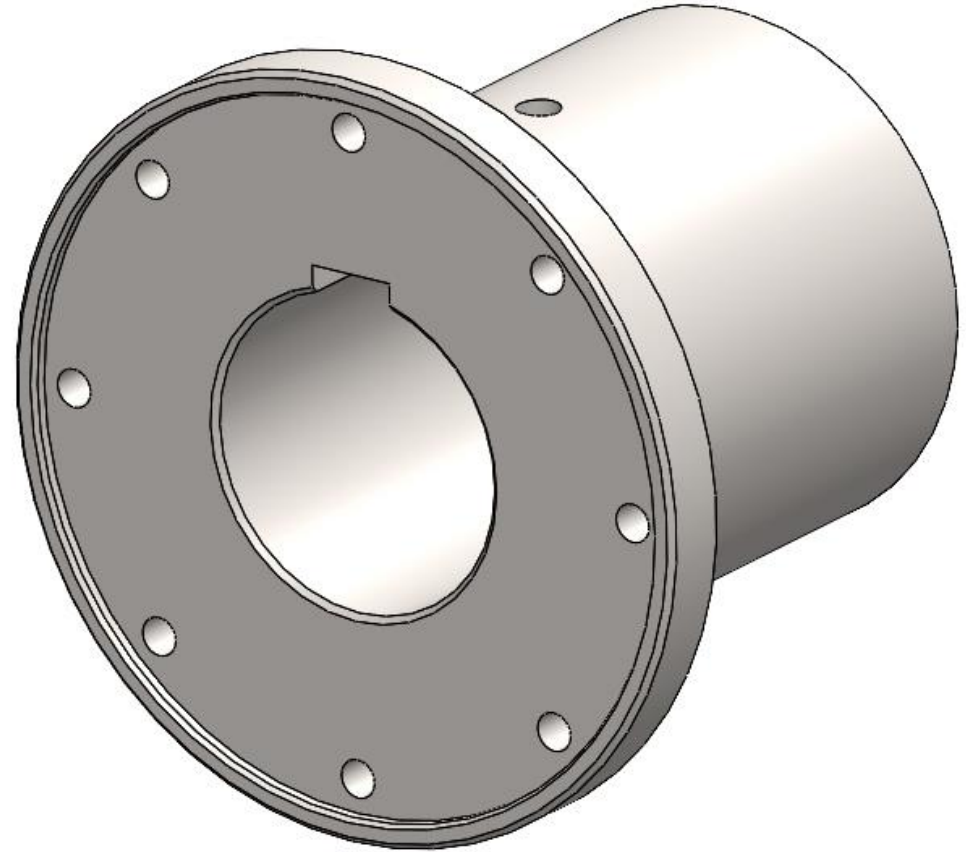

CONNECTING FLANGES DIN ISO 14

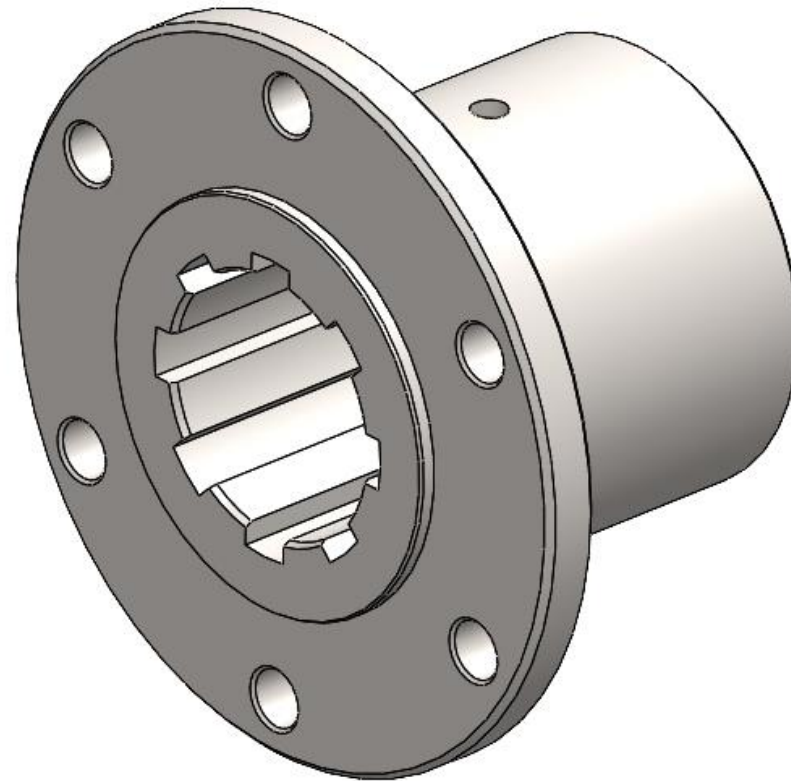

CONNECTING FLANGES XS ISO 8667

PROFILE FOR TORQUE TRANSMISSION

key groove DIN 6885

involute spline DIN 5480

involute spline DIN 5482

involute spline ANSI B92.1

parallel spline DIN ISO 14

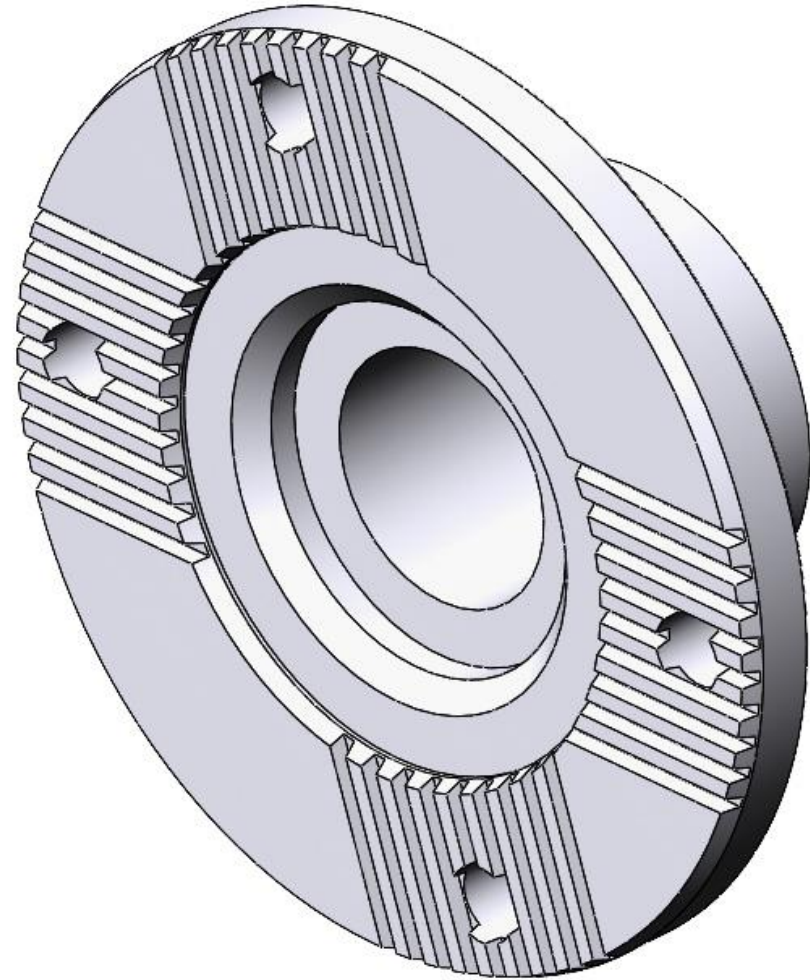

PROFILE SHAFTS :

shaft length– 2m
length of grooves– 1,6m
modul 0,5 - 6

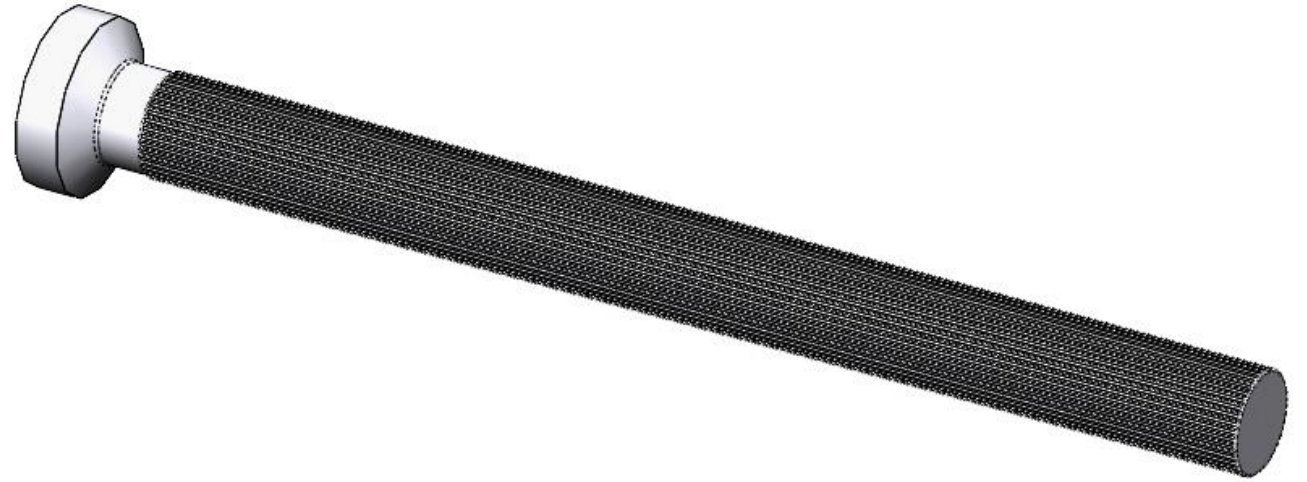

HUB SLEEVES:

maximum length – 350 mm
modul 0,5 - 6

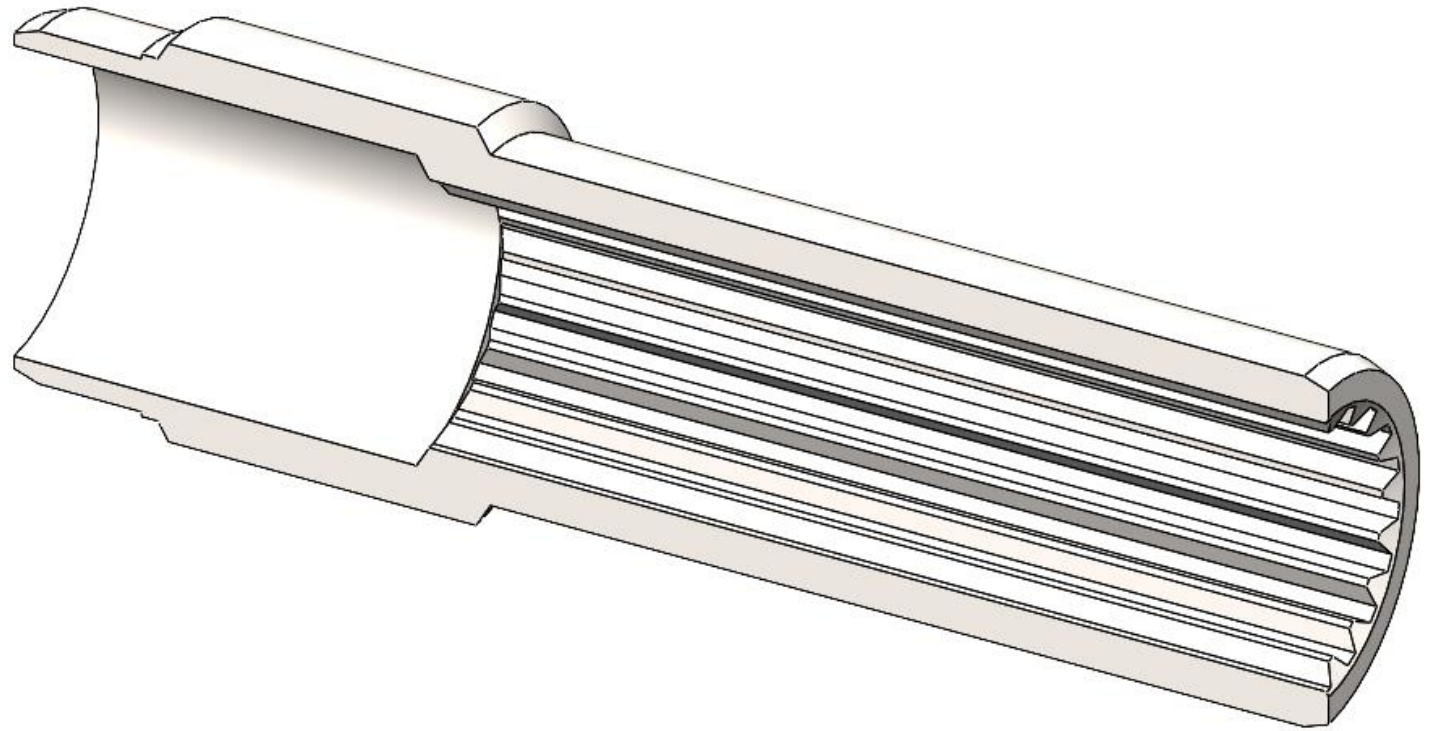

EDM

length max. 350 mm

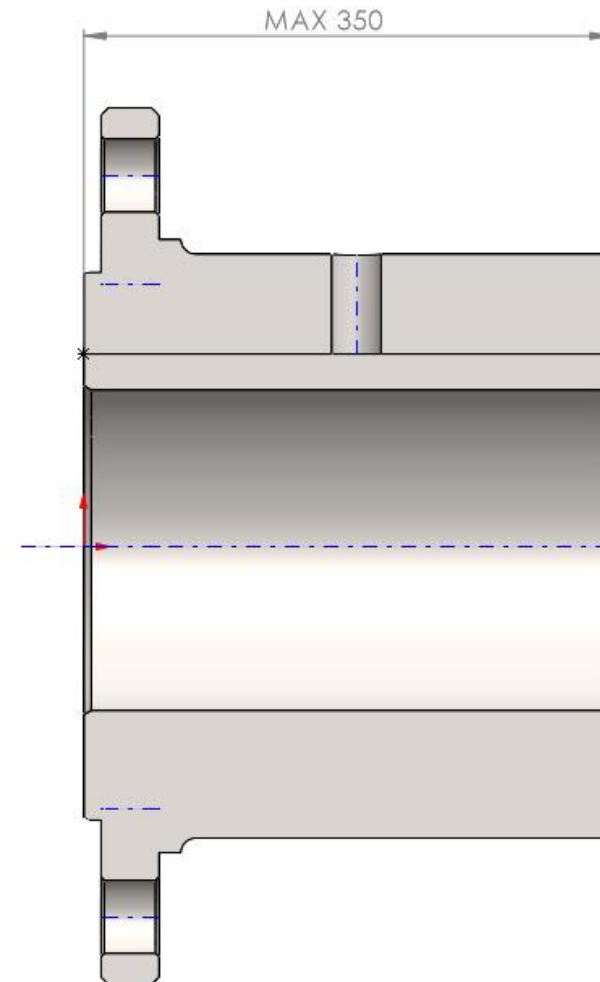

Special production of extra
short cardan couplings
Mechanics 2C - 10C

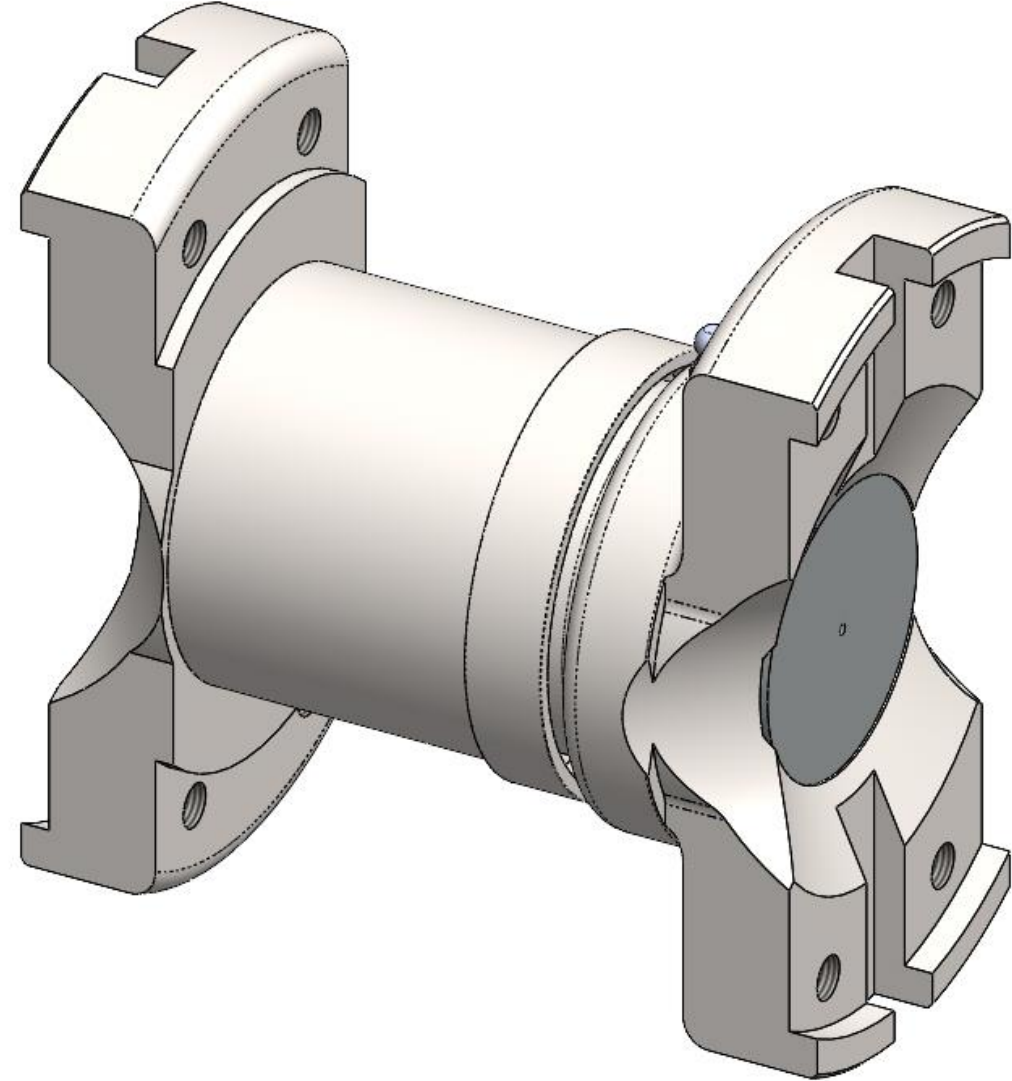

Special production of extra
short cardan couplings
Mk 100 – 80 000 Nm

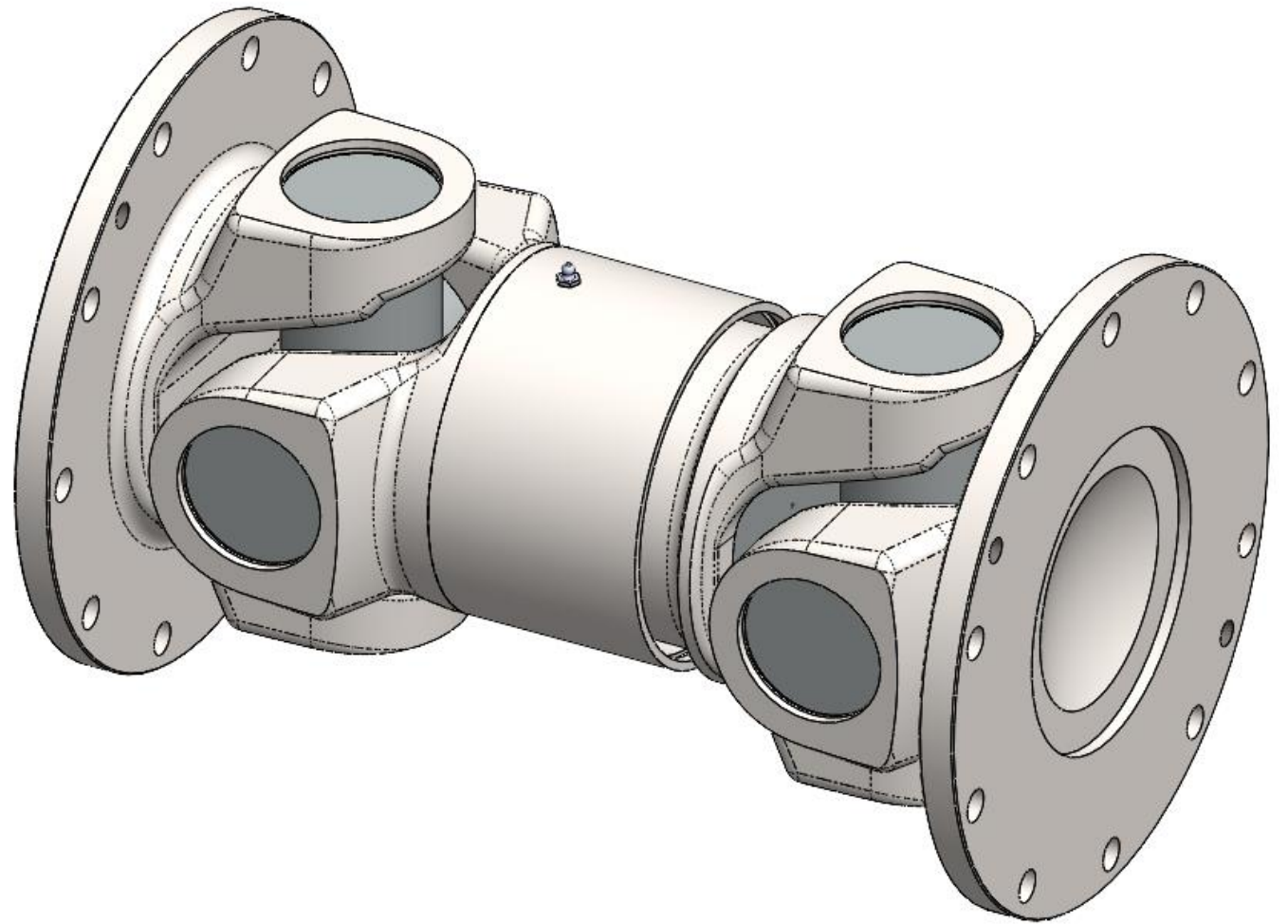

Production of other special parts according to drawing documentation.

- **Contact**

- Processing of offers:

Lenka Lochmanová: lochmanova.lenka@ml-tuning.cz

Dušan Dragoun: dragoun.dusan@ml-tuning.cz

Lukáš Krupka: krupka.lukas@ml-tuning.cz

- Construction:

Lukáš Krupka: krupka.lukas@ml-tuning.cz